

## 1811-L

### WHEELED WORK BENCH

- sturdy double-walled sheet steel construction
- scratch resistant, powder coated, ELORA-yellow (RAL 1006), door/drawers black (RAL 9006)
- Storage surface made of PS (polystyrene), solvent-resistant, with integrated storage compartments
- 7 drawers with ball bearings and full-extension runners
- individual drawer locking over the whole ledge (one-hand operation)
- drawer internal measurements W 573 x D 410 mm
- drawers ELORA-black powder-coated (RAL 9005)
- central locking system with cylinder lock and 2 keys
- anti-tilt device (prevents several drawers from opening at the same time)
- load capacity per drawer: 45 kg
- door side with one shelf
- stable handle
- 2 fixed and 2 braked swivel castors
- total load capacity 450 kg
- suitable assortments: all OMS-Modules

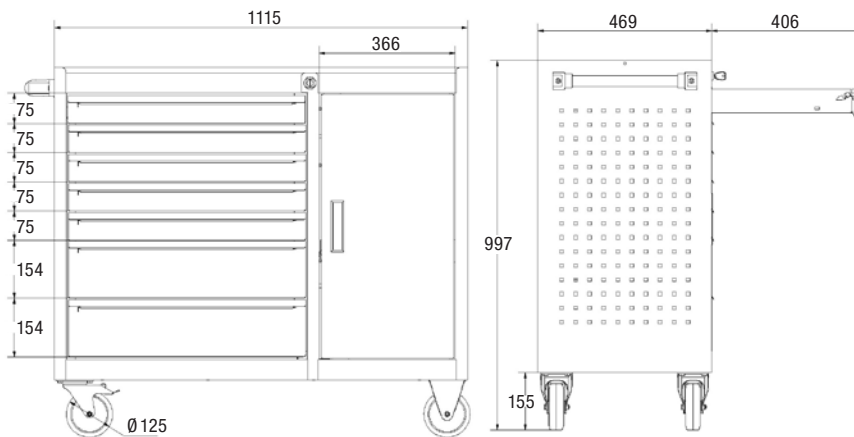

Code	Number	Width mm	Height mm	Depth mm	Pieces	Weight/g
1811500006100	1811-L	1115	997	469	1	80000

## 1200-RM 18

### ANTI SLIP MAT

- for drawers in tool cabinets and work benches
- Length: 2m



Code	Number	Width mm	Pieces	Weight/g
1200004752000	1200-RM 18	475	1	650